

# PKS-PRO-E-10 - Servo System

FEATURES

- **Input Voltage Range of 170-253 VAC**
- **Rated Torque of 450-1,352 oz-in**
- **1.0 kWatt Power Rating**
- **2,500 PPR Incremental Encoder**
- **Fully Enclosed and Self-Cooled**
- **Oil Seal and Optional Brake**
- **High Overload Capacity**
- **MODBUS and CANopen Standard**
- **RS485 Interface**
- **Real Time Monitoring and Management**
- **Position, Speed, and Torque Control**



DESCRIPTION

The PKS-PRO-E-10 servo system includes a 1.0 kWatt EMG, EMJ or EML AC Servo Motor operated by the PRONET drive. These packages are ideal for quick and easy start-ups, convenience and performance! The servo motor included in this package provides torque from 450 to 1,352 oz-in. The PRONET drives offer current forward-feedback control, acceleration forward-feedback control, speed viewer, and inertia viewer; providing for improved response performance. These drives operate standard with MODBUS and CANopen protocol. Each system includes a 5M power cable, 5M encoder cable, and a 3M communication cable.

System Specs	Rated Speed (RPM)	Rated Torque (oz-in)	Rated Current (A rms)	Inertia (oz-in-sec <sup>2</sup> )	Torque Constant KT (oz-in/A)	Resistance (ohms)	Inductance (mH)	Driver Digital Display	Brake (24VDC)	Motor Length (mm)	Shaft Diameter (mm)
PKS-PRO-E-10-A-GP22	2000	667	6.0	0.1416	123.1	0.7	7.9	Yes	No	215	22
PKS-PRO-E-10-A-GP24	2000	667	6.0	0.1501	123.1	0.7	7.9	Yes	Yes	269.5	22
PKS-PRO-E-10-B-JP22	3000	450	5.3	0.0246	86.8	1.6	11.9	Yes	No	211	19
PKS-PRO-E-10-B-JP24	3000	450	5.3	0.0265	86.8	1.6	11.9	Yes	Yes	254	19
PKS-PRO-E-10-A-LP22	1000	1352	6.0	0.2691	265.2	1.1	15.4	Yes	No	265	22
PKS-PRO-E-10-A-LP24	1000	1352	6.0	0.2776	265.2	1.1	15.4	Yes	Yes	319.5	22

ORDERING INFORMATION

## PKS-PRO - E - 10 - A - J P 2 2

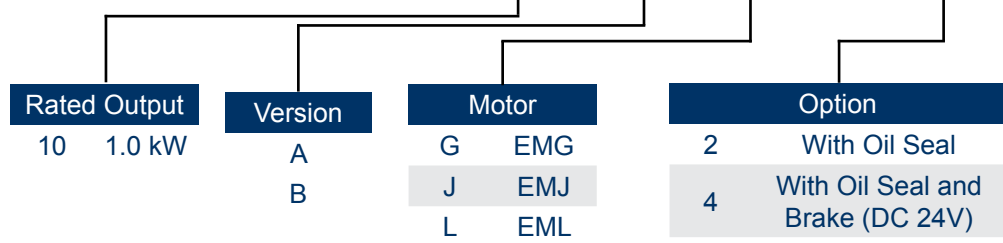

\*Note: B Version is only available for EMJ Series.

L010956

# EMG-10 Motor Specifications

FEATURES

- **Rated Torque of 677 oz-in**
- **3-Phase, 200VAC**
- **Medium Inertia to Maximize Torque**
- **Peak Torque up to 300% of Rated Torque**
- **Peak Current up to 300% of Rated Current**
- **Speed of up to 3,000 RPM**
- **2,500 PPR Incremental Encoder Attached**
- **Power Rating up to 1.0 kWatts**
- **Oil Seal and Optional Brake**
- **Long Life and Highly Reliable**
- **Neodymium-Iron-Boron Magnets (NdFeB)**
- **CE Certified**



SPECS

Model #	Rated Torque (oz-in)	Rated Power (Watts)	Rated Speed (rpm)	Rated Current (A rms)	Brake (24VDC)	Inertia (oz-in-sec <sup>2</sup> )	Electric Time Constant T <sub>E</sub> (ms)	Back EMF Voltage K <sub>E</sub> (V/krpm)	Torque Constant K <sub>T</sub> (oz-in/A)	Resistance (ohms)	Weight (lbs)
EMG-10APA22	677	1000	2000	6.0	No	0.1416	11.57	60.9	123.1	0.7	17.64
EMG-10APA24	677	1000	2000	6.0	Yes	0.1501	11.57	60.9	123.1	0.7	17.64

DIMENSIONS

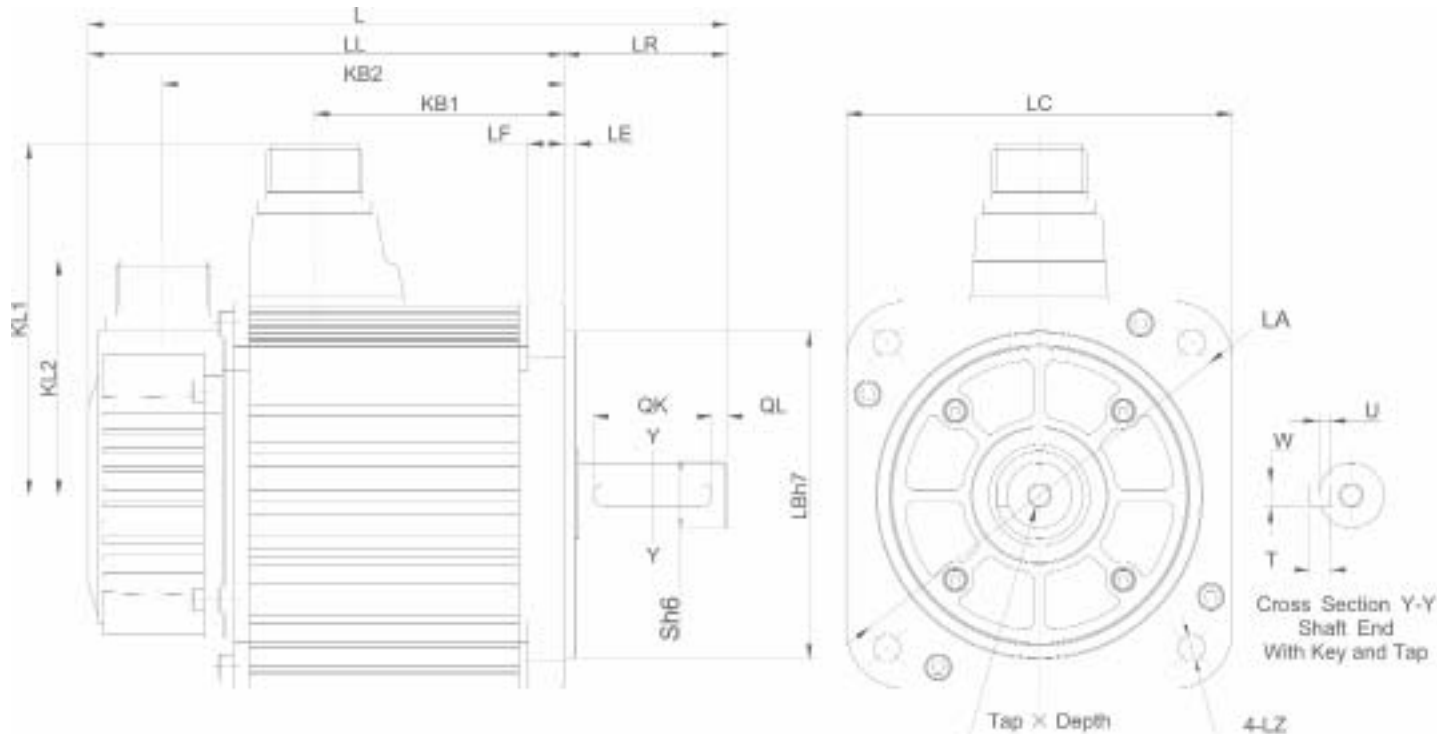

Note: All Dimensions in (mm)

MODEL #	L	LL	KB1	KB2	KL1	KL2	FLANGE SLIDE							S	TapxDepth	KEY				
							LR	LE	LF	LC	LA	LB	LZ			QK	QL	W	T	U
EMG-10APA22	215	160	84	135	118	79	55	4	12	130	145	110	9	22	M6x20L	40	5	8	7	4
EMG-10APA24	269.5	214.5	84	189.5	118	79	55	4	12	130	145	110	9	22	M6x20L	40	5	8	7	4

# EMJ-10 Motor Specifications



FEATURES

- **Rated Torque of 450 oz-in**
- **3-Phase, 200VAC**
- **Peak Torque up to 300% of Rated Torque**
- **Peak Current up to 300% of Rated Current**
- **Speed of up to 4,500 RPM**
- **2,500 PPR Incremental Encoder Attached**
- **Power Ratings up to 1.0 kWatts**
- **Optional Brake and Oil Seal**
- **Long Life and Highly Reliable**
- **Neodymium-Iron-Boron Magnets (NdFeB)**
- **CE Certified**



SPECS

Model #	Rated Torque (oz-in)	Rated Power (Watts)	Rated Speed (rpm)	Rated Current (A rms)	Brake (24VDC)	Inertia (oz-in-sec <sup>2</sup> )	Electric Time Constant T <sub>E</sub> (ms)	Back EMF Voltage K <sub>E</sub> (V/krpm)	Torque Constant K <sub>T</sub> (oz-in/A)	Resistance (ohms)	Weight (lbs)
EMJ-10BPA22	450	1000	3000	5.3	No	0.0246	9.9	38.4	86.8	1.6	9.93
EMJ-10BPA24	450	1000	3000	5.3	Yes	0.0265	9.9	38.4	86.8	1.6	9.93

DIMENSIONS

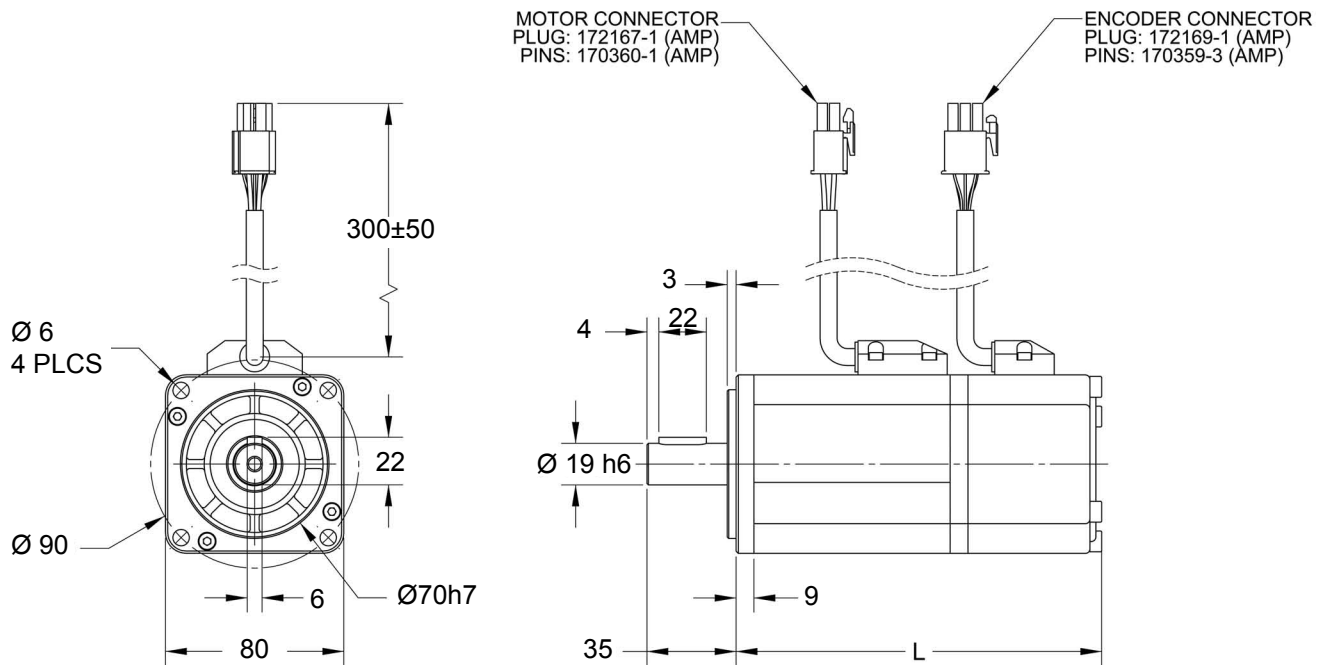

Model #	L
EMJ-10BPA22	176
EMJ-10BPA24	219

Note: All Dimensions in millimeters (mm)

Note: Part Number EMJ-10BPA24 is with the brake option. The length of 'L' includes the motor body length + the length of the brake.



# EML-10 Motor Specifications

FEATURES

- Torque Rating of 1,352 oz.-in.
- 3-Phase, 200VAC
- Medium Inertia to Maximize Torque
- Peak Torque up to 300% of Rated Torque
- Peak Current up to 300% of Rated Current
- Speed of up to 1,500 RPM
- 2,500 PPR Incremental Encoder Attached
- Power Rating up to 1.0 kWatts
- Oil Seal, and Optional Brake
- Long Life and Highly Reliable
- Neodymium-Iron-Boron Magnets (NdFeB)
- CE Certified



SPECS

Model #	Rated Torque (oz-in)	Rated Power (Watts)	Rated Speed (rpm)	Rated Current (A rms)	Brake (24VDC)	Inertia (oz-in-sec <sup>2</sup> )	Electric Time Constant T <sub>E</sub> (ms)	Back EMF Voltage K <sub>E</sub> (V/krpm)	Torque Constant K <sub>T</sub> (oz-in/A)	Resistance (ohms)	Weight (lbs)
EML-10APA22	1352	1000	1000	6.0	No	0.2691	14.09	122	265.2	1.1	28.67
EML-10APA24	1352	1000	1000	6.0	Yes	0.2776	14.09	122	265.2	1.1	28.67

DIMENSIONS

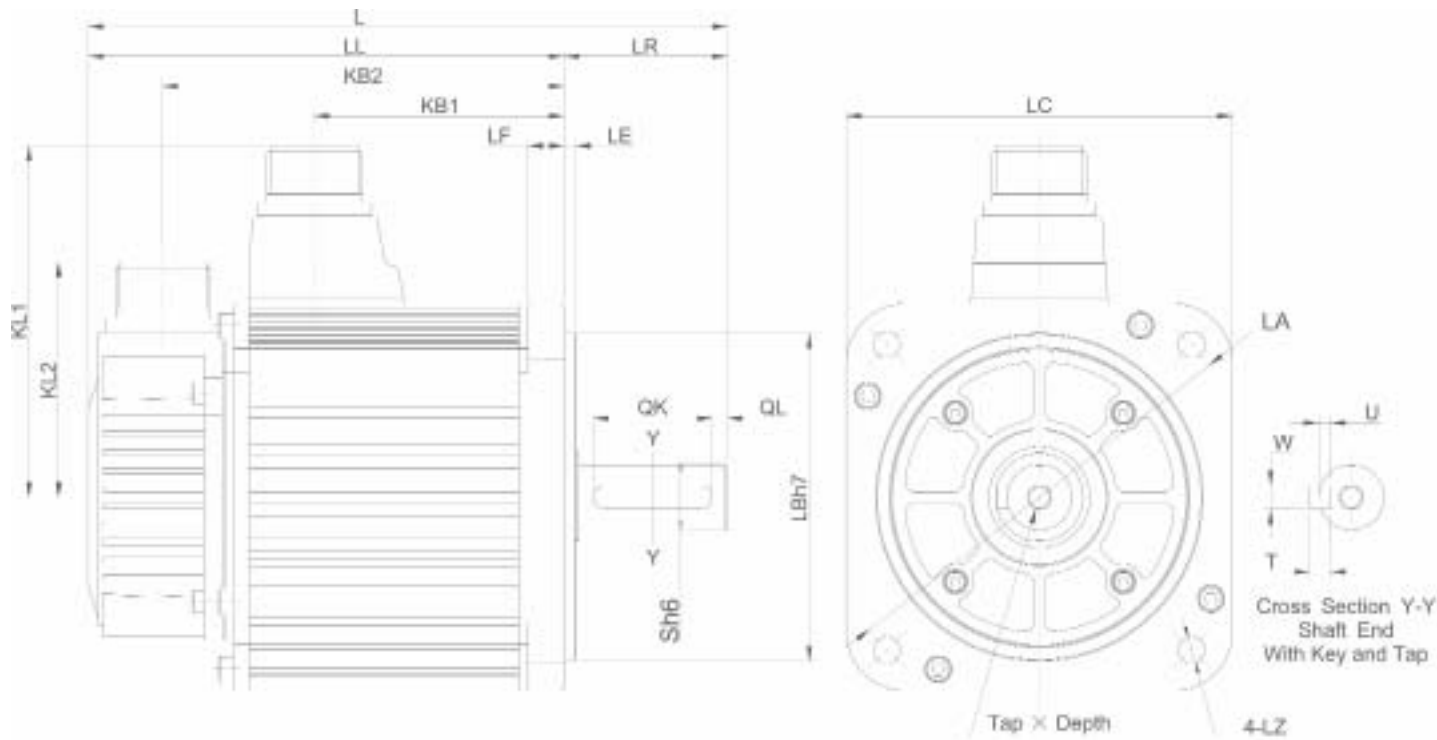

Note: All Dimensions in (mm)

MODEL #	L	LL	KB1	KB2	KL1	KL2	FLANGE SLIDE							S	TapxDepth	KEY				
							LR	LE	LF	LC	LA	LB	LZ			QK	QL	W	T	U
EML-10APA22	265	210	134	185	118	79	55	4	12	130	145	110	9	22	M6x20L	40	5	8	7	4
EML-10APA24	319.5	264.5	134	187.5	118	79	55	4	12	130	145	110	9	22	M6x20L	40	5	8	7	4

# PRO-E-10 Driver Specifications

## FEATURES

- Input Voltage Range of 170-253 VAC
- Rated Power up to 1.0 kWatts
- Improved Responsiveness Performance
- Enhanced Position Precision
- Low Speed Stability
- Enables Less Debugging
- MODBUS and CANopen Standard
- RS485 Interface
- Position, Speed, and Torque Control
- Homing Function



## ProNet DIMENSIONS

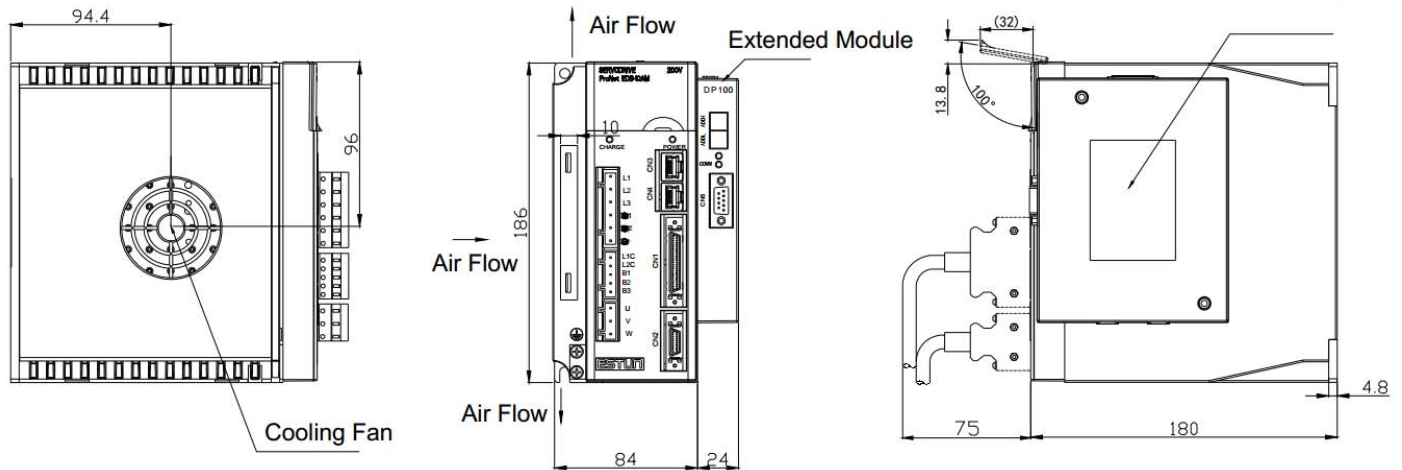

Dimensions are in mm

## TORQUE CURVE

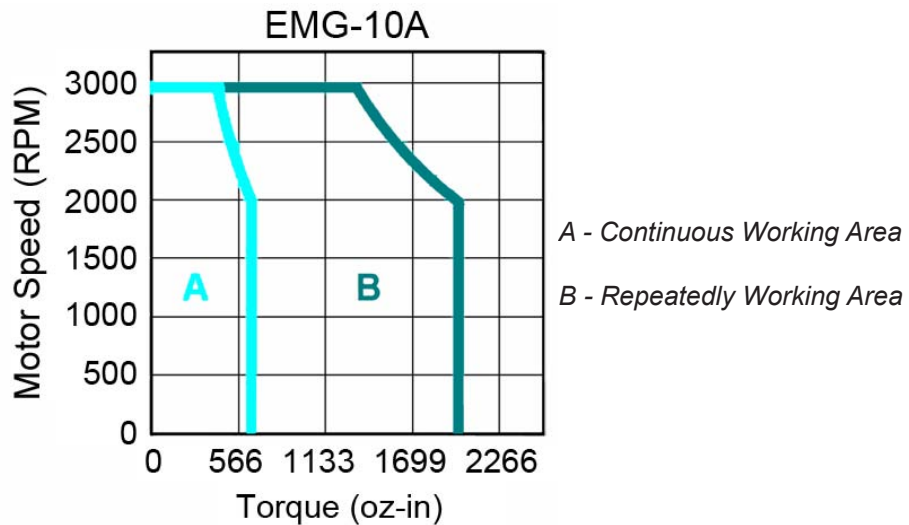

EMJ-10A

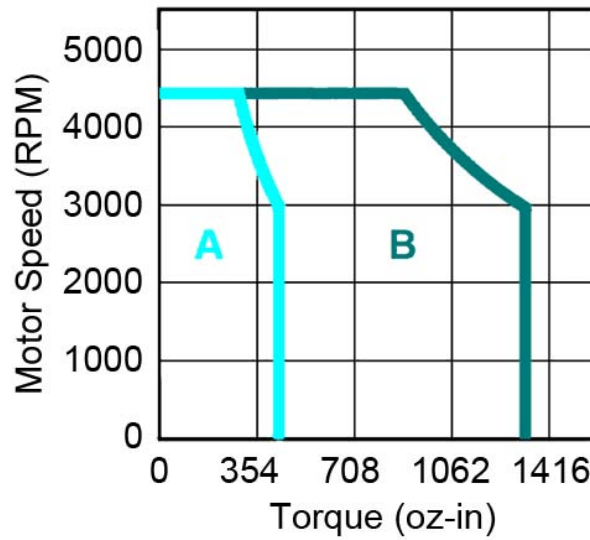

A - Continuous Working Area

B - Repeatedly Working Area

EML-10A

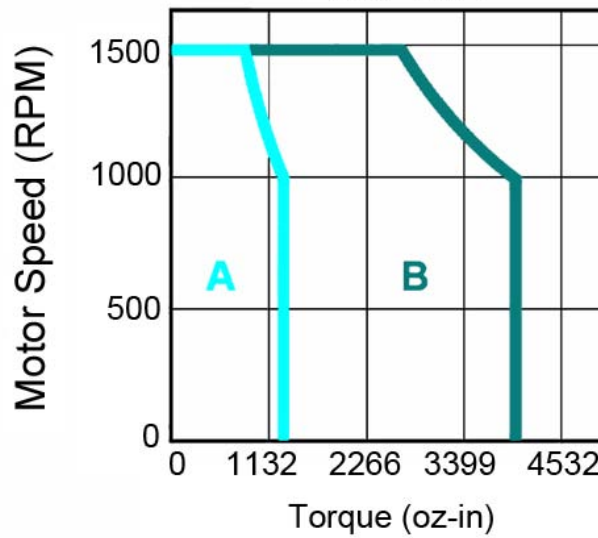

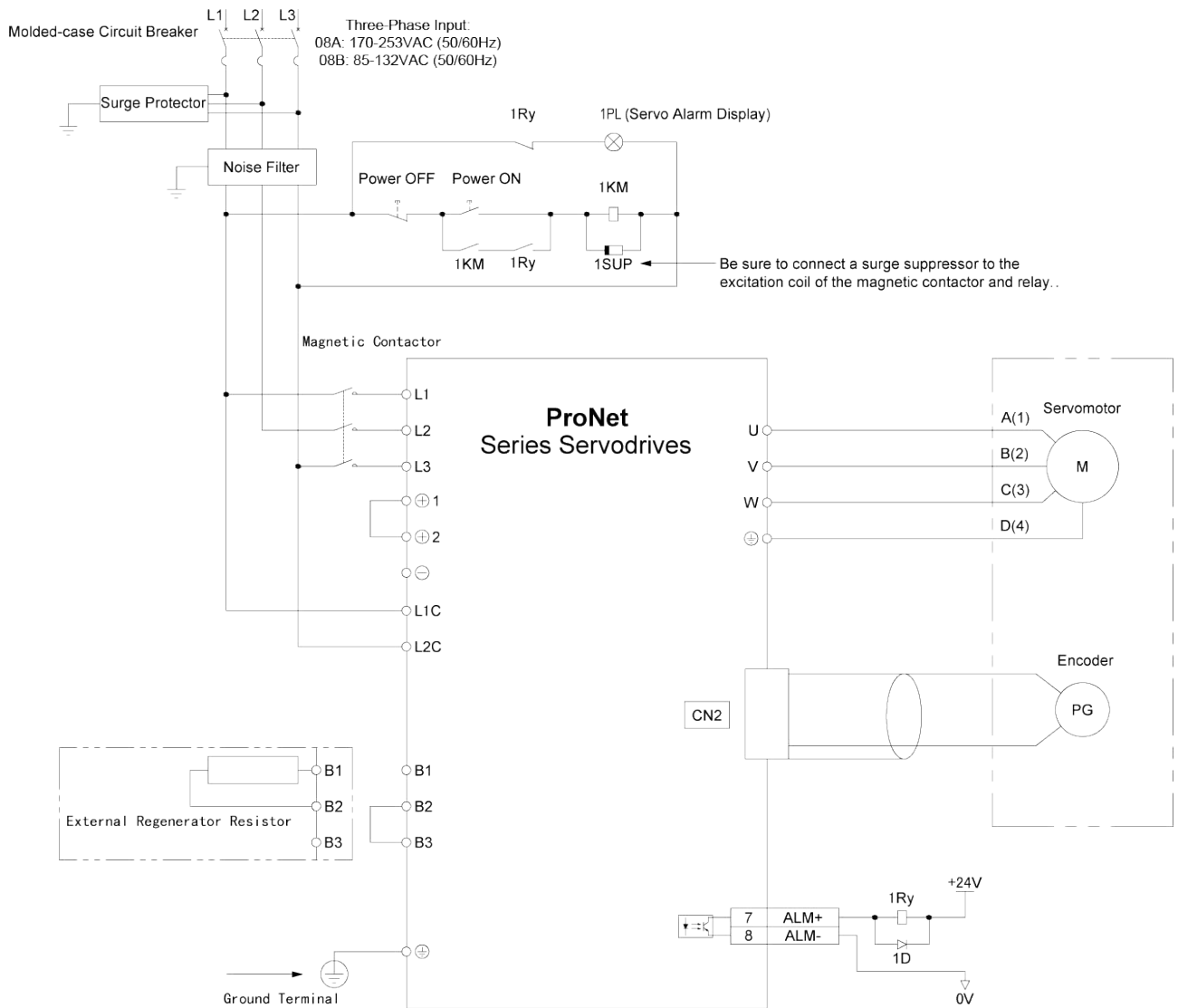



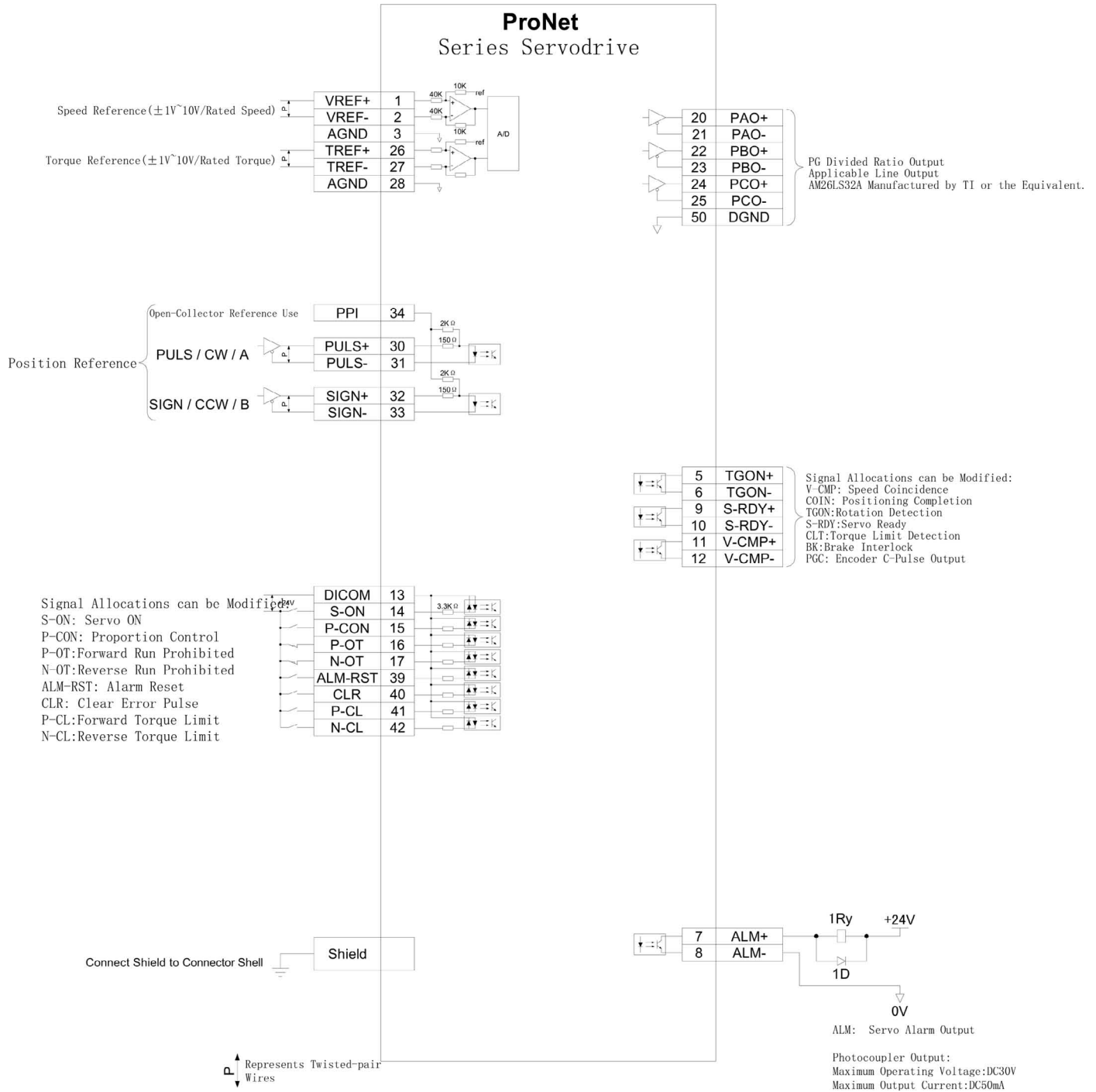



### Compatible Drivers

Part Number	Description
PRONET-E-10A	Servo Driver



### Compatible Motors

Part Number	Description
EMG-10APA22	Servo Motor
EMG-10APA24	Servo Motor
EMJ-10BPA22	Servo Motor
EMJ-10BPA24	Servo Motor
EML-10APA22	Servo Motor
EML-10APA24	Servo Motor



### Compatible Cables

Part Number	Description
PDM-GA16-05	Power Cable
BMP-GA24-05	Encoder Cable
PRONET-PSC-CC24-02	Comm. Cable

